

INSTALLATION INSTRUCTIONS

AMMETER GAUGE
VOLTMETER GAUGE
TEMPERATURE GAUGE
PRESSURE GAUGE
VACUUM/ECONOMETER/
BOOST GAUGE
FUEL PRESSURE GAUGE
FUEL LEVEL GAUGE

GENERAL MOUNTING INSTRUCTIONS

Actron produces a full line of gauges with many different styles.

- 1-1/2" — "Mini" Black Bezel
- 2" — Black and Chrome Bezels
- 2-5/8" — Black Bezel with Chrome Snap-on Bezel

(See page 2 for hole sizes.)

Gauges allow you to monitor the condition of your vehicle and to tell how well it is performing. If there are any problems, you can detect them immediately before they become severe. Warning lights only tell you when the problem already requires immediate attention. You will find that the addition of these gauges will add to your peace of mind and driving comfort.

MICROPROCESSOR-CONTROLLED ENGINES

Many newer vehicles employ microprocessors that control most of the engine and electrical functions. Microprocessors are very sensitive electrical components. Before installing any aftermarket equipment consult the vehicle's manufacturer or shop manual to make certain that no damage will result.

Some of these newer vehicles use electric cooling fans or microprocessor engine controls that depend on readings

from the original equipment sending units for correct operation. If your vehicle is one of these you CANNOT replace the sender(s) with any other. You can add an additional oil pressure sender with a "Tee Adapter Kit" but the only possible way to install a non OEM water temperature sender is to install the new sender in a different location, retaining the OEM unit in its original location. Check with the vehicle's manufacturer or dealer to see if this is possible.

INSTALLATION & SAFETY PRECAUTIONS

1. Read the entire instructions for your gauge before proceeding.
2. Be sure the gauge is suitable for your vehicle:
 - Does the gauge's range cover the vehicle's operating range?
 - Will the tubing of the mechanical gauges reach from the engine connection point to the gauge (temperature gauges cannot be lengthened)?
3. Is the vehicle's electrical system 12 volt and negatively grounded?
3. It is recommended that the battery ground cable be disconnected before any electrical work is performed, especially when installing Ammeters or Voltmeters.
4. Route all wiring and gauge tubing away from linkages, high heat or moving parts.

- Never smoke while working on your vehicle and always keep a fire extinguisher nearby. It should be rated for gas/chemical/electrical fires.
- Never lay tools on top of the battery or wear jewelry during electrical work to avoid severe electrical shorts.

GAUGE MOUNTING

All Actron gauges can be mounted into a surface of your choice or into a panel. Single, dual & triple gauge mounting panels are produced by Actron for all size gauges. Some panels are in black or chrome finishes. A fully chromed mounting cup is available for the 2-5/8" gauges.

- Choose a location to mount the gauge where it will be viewable from a normal driving position (fuel pressure gauges should never be mounted within the interior of the vehicle).
- If you are using a mounting panel, mount it at the chosen location with the screws provided.

Diagram 1

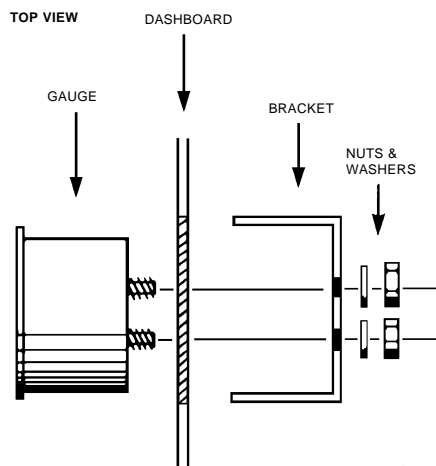

If you are creating a hole, make the hole:

GAUGE STYLE	HOLE SIZE
1-1/2"	1-5/8" (41 mm)
2"	2-1/16" (53 mm)
2-5/8"	2-5/8" (67 mm)

- For dash lighting dimmers that control the positive side (Diagram 2A) of the lighting circuit:

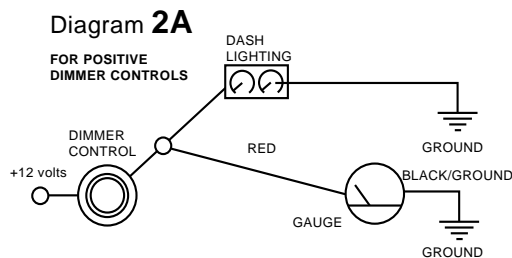

- FOR TWO-WIRE BULB HOLDER— connect the red wire into the circuit between the dimmer control and the dash lights. Connect the black wire to a good electrical ground.

- FOR ONE-WIRE BULB HOLDER — connect the one wire into the circuit between the dimmer control and the dash lights. Obtain a length of 18-gauge insulated copper wire and connect one end of the wire to a good electrical ground source and the other end to one of the mounting bracket posts.

- For dash lighting dimmers that control the grounded side (Diagram 2B) of the lighting circuit:

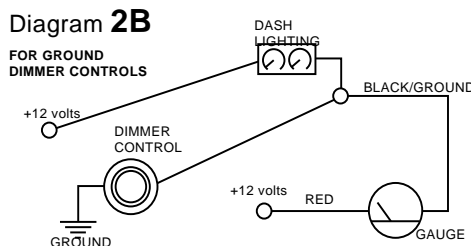

- FOR TWO-WIRE BULB HOLDER — connect the black wire into the circuit between the dimmer control and the dash lights. Connect the red wire to the fuse box so that the wire only receives +12-volt power when the dash lights are turned on.

- FOR ONE-WIRE BULB HOLDER —

Connect the wire to the fuse box so it receives only +12-volt power when the dash lights are on. Obtain a length of 18-gauge insulated copper wire and connect one end to the gauge mounting bracket or panel. Connect the other end of the wire into the circuit between the dimmer control and the dash lights. Insulate the gauge and bracket from grounded surfaces.

- Refer to specific instructions for the gauge you are installing. They explain other connections that should be made before mounting is completed.
- Insert the gauge into the mounting panel or hole.
- Insert the bulb holder into the bulb socket on the back of the gauge.
- Install the appropriate mounting bracket (Diagram 1: insulated or non-
- Position the gauge for best visibility and appearance, then tighten the bracket nuts with moderate pressure. Do not over-tighten these nuts when using an insulated bracket. Excess pressure can distort the grommets causing them to crack and short the wiring, even months after installation.
- Refer to the specific instructions for the gauge you are now installing to complete any other connections.

Diagram 3
Electrical Gauges Shown

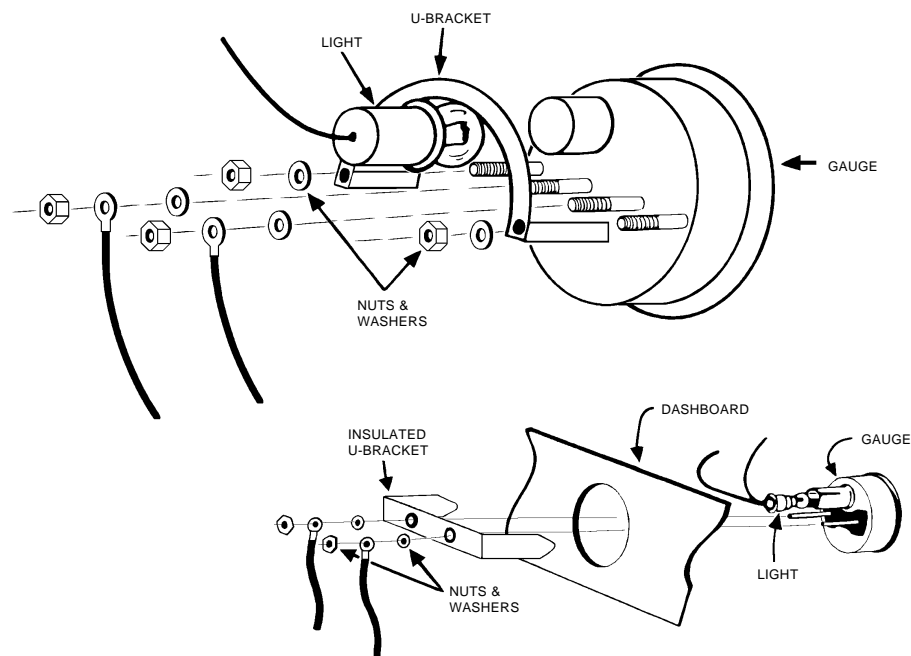

AMMETER — INSTRUCTIONS

An ammeter measures the amperage (volume of electricity) passing through it. The goal of installation is to reroute all the power through the ammeter (Diagram 4) that drains or charges the battery, except the power needed to operate the starter motor. When the vehicle is operating above idle speed, the ammeter should be indicating "0", or a slight charge condition, which shows a balance of charging and drain on the battery.

Read all precautions and installation instructions carefully before proceeding with any installation work as the potential for electrical damage or fire exists if an ammeter is improperly connected.

PRECAUTIONS

1. Never ground either of the connection posts for the ammeter.
2. Always use a wire size that is rated to handle an electrical load equal to or greater than the manufacturer's

Diagram 4

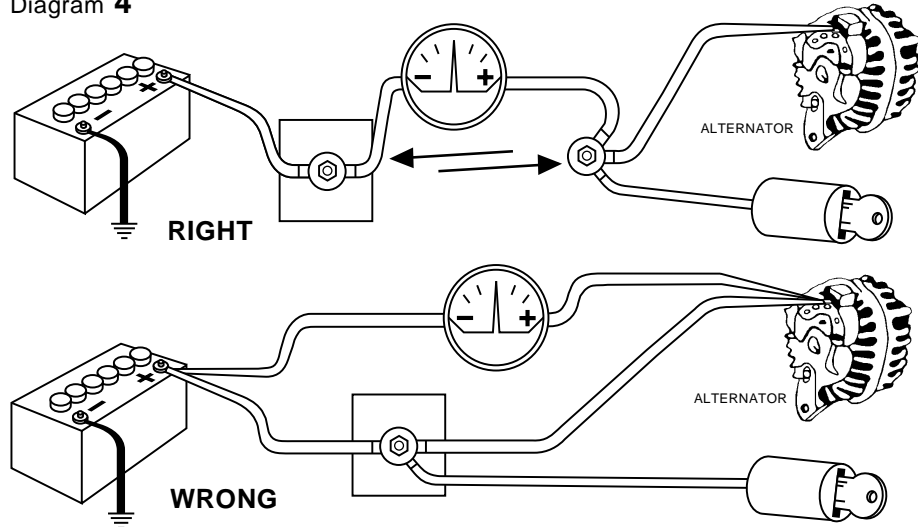

specified output of your alternator/generator.

3. Never connect the ammeter into the circuit between the battery and the starter/solenoid.
4. Good electrical connections are important for maintaining gauge accuracy and avoiding heat buildup in the wiring.

INSTALLATION

As the many different vehicles that have been produced have minor differences in the routing and connection points of their charging systems, it is not possible for Actron to provide specific information for each vehicle. The eight drawings of Diagram 5 cover the relevant connection points of virtually every charging system in modern vehicles. You will need to determine which drawing matches your system. If you have difficulty in locating any of these connection points refer to a wiring diagram in an owner/service manual or contact your local dealer/auto electrical repair shop for assistance.

Diagram 5

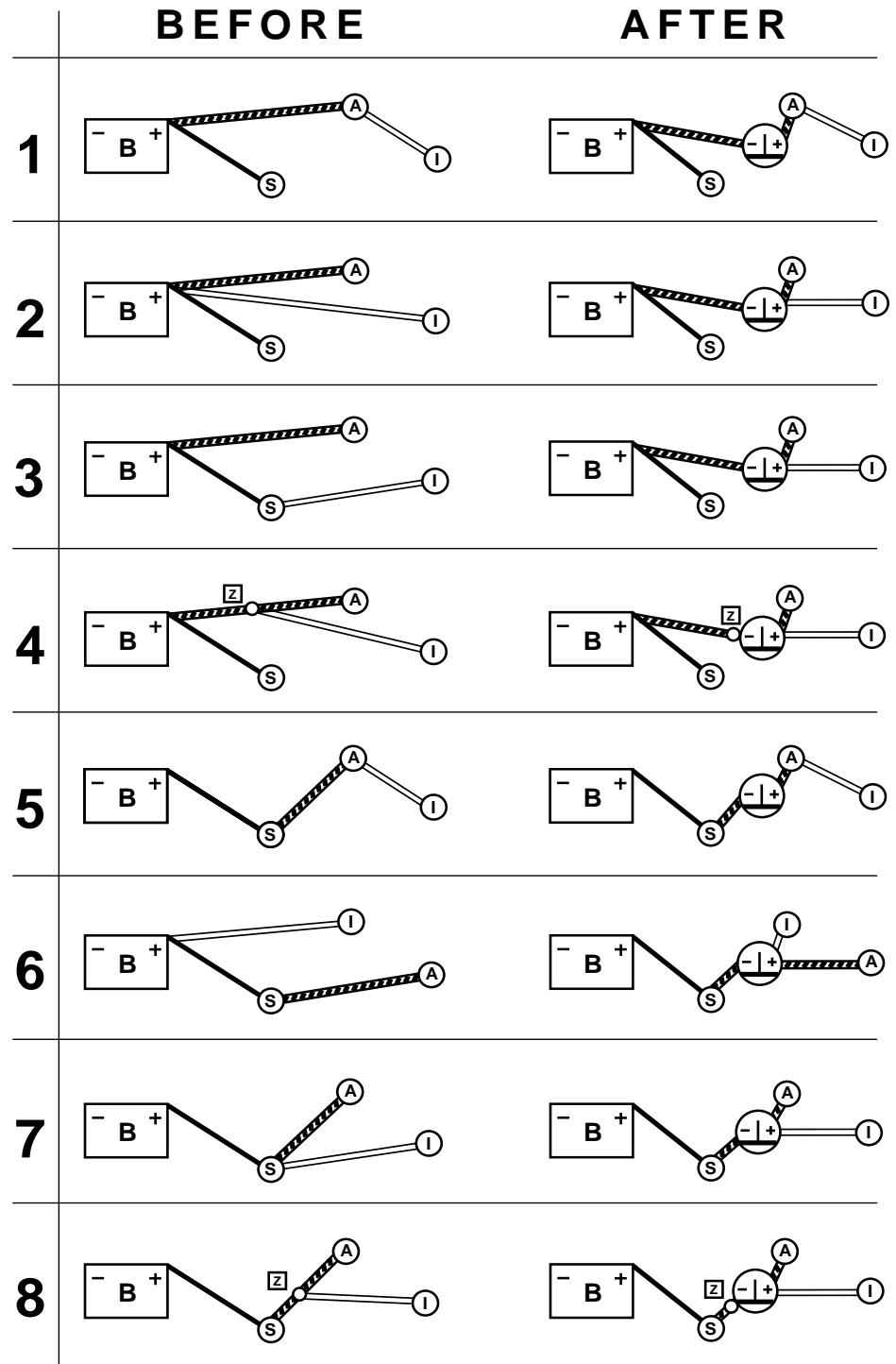

The following connection points are represented in the drawings of Diagram 5:

- B- Battery: the positive terminal
- S- Starter/Solenoid: the main power wire to the battery (largest wire)
- A- Alternator/Generator: the main power wire to the battery (largest wire at alternator) and, in Drawings 1 & 5, the wire from the ignition/accessories
- I- Ignition/Accessory: the main power wire, which receives power regardless of ignition key position
- Z- Junction: in Drawings 4 & 8, where "I" connects into the circuit

Note: The circuit from the battery (B) to alternator (A) or starter (S) to alternator (A) may also contain a junction block, horn relay or headlight relay, which is not shown. One of these is likely to be connection "Z" in Drawings 4 & 8. These locations are often handy connections that you can disconnect and then attach the ammeter wires to.

1. After you have identified which BEFORE Drawing represents your charging system, observe the corresponding AFTER Drawing which indicates how to connect the ammeter into your charging system.
2. Find a convenient location in the circuit from the battery to the alternator (Drawings 1 - 4) or the starter to the alternator circuit (Drawings 5 - 8) where you can break the circuit by unbolting a connection. In Drawings 4 & 8, this should be at Connection "Z".
3. If your system matches Drawings 2, 3 or 6, disconnect the Ignition/Accessory (I) wire at "B" or "S".
4. Choose a wire size from the table in Diagram 6 that is a large enough gauge (larger size wire has a smaller gauge number) to handle the maximum rated output of your vehicle's

alternator/generator. Obtain two lengths of this size wire that are each long enough to go from the location that was chosen in Step 2, to the ammeter's mounting location at the dashboard. Attach closed-eyed type connectors (Diagram 7, page 7), to each end of both wires.

Diagram 6

WIRE SIZE	MAX. AMP. RATING
12	25
10	40
8	65
6	95
4	125

5. At the location you chose in Step 2, disconnect all the wires at the connection except the wire going to the battery.
6. Connect an end of one of the wires you obtained in Step 4 to all the wires you disconnected in Step 5.
7. Connect an end of the remaining wire from Step 4 to the connection in Step 5 that still has the battery wire attached to it.
8. If your system matches Drawings 2, 3, or 6, connect the wire you disconnected in Step 3 to the wires already connected in Step 6. Use an additional piece of similar sized wire to join these wires, if necessary.
9. Insulate all connections and use a suitable method to fasten down the wires in Step 6 and 8.
10. Route the two ammeter wires to the mounting location for the ammeter. Insulate the opening in the firewall they pass through.
11. Mount the gauge and attach the remaining end of the wire from Step 6 to the ammeter connection post marked with a "+". Follow the sequence of washer-wire-nut shown in Diagram 7, page 7.

12. Attach the remaining end of the wire from Step 7 to the ammeter connection post marked with a "-" sign, again following Diagram 7, page 7.
13. Reconnect the battery ground cable. As you do, watch for sparks and check if the wiring you worked with is getting warm. If either condition is noted, IMMEDIATELY disconnect the battery ground cable and read the Troubleshooting section.

TROUBLESHOOTING

1. If, when you reconnected the battery ground cable, you noticed sparks or any of the wiring getting warm, check that all connections are properly located, and insulated from grounding.
2. With the vehicle not running and the battery reconnected, turn on the headlights' high beam and observe the ammeter. The gauge should show a drain (-) condition. If a charge (+) condition is shown, reverse the wires on the "+" and "-" posts on the back of the ammeter. If the ammeter shows no change, the circuit from Ignition/Accessory (I) has not been properly included in the connections to the "+" side of the gauge.

Diagram 7

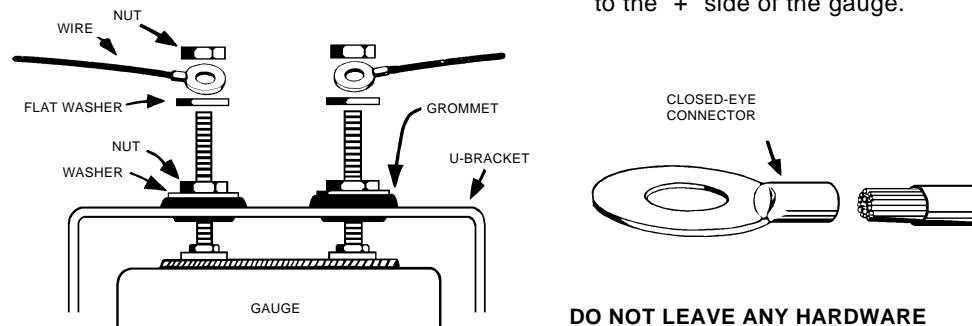

DO NOT LEAVE ANY HARDWARE OUT OF THESE CONNECTIONS

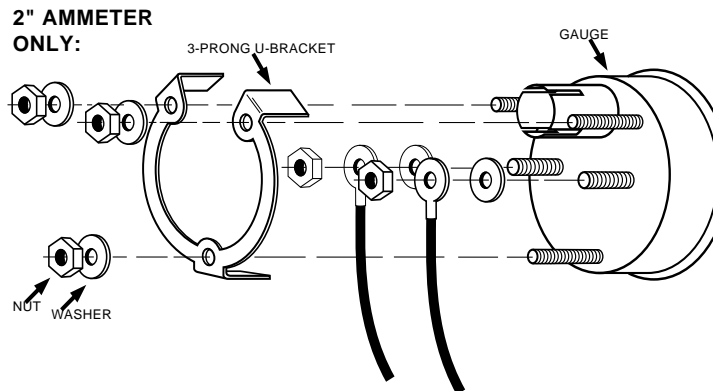

VOLTMETER — INSTRUCTIONS

A voltmeter measures the voltage (pressure of electricity) passing through it. Most vehicles will show between 13 and 15 volts while being operated above idle speed. Check your owners manual or dealer for a more exact normal voltage for your vehicle. A voltmeter is useful in that it can give a warning of many electrical problems and can show many problems faster than an ammeter.

PRECAUTIONS

1. Follow the instructions carefully for the sequence of nuts and washers on the connection posts of the voltmeter (Diagram 7, page 7).
2. Disconnect the battery's ground cable before working on the voltmeter connections.

INSTALLATION

1. Connect a length of 18-gauge insulated copper wire to a good ground source. Be sure the grounding surface is a good ground source as not all metal surfaces inside the vehicle are well grounded. This wire should be long enough to reach the voltmeter's mounting location.
2. Connect another length of 18-gauge wire to a location on the fuse box where the wire will receive power whenever the ignition key is in the START, ON or ACCESSORY posi-

tions. This wire should also be long enough to reach the voltmeter.

3. After mounting the gauge, the wire from the ground source (Step 1) should be connected as shown in Diagram 7, page 7, to the voltmeter's connection post marked "−"
4. The wire from the fuse box (Step 2) should be connected as shown in Diagram 7, page 7, to the voltmeter's connection post marked "+".
5. Reconnect the battery ground cable. As you do, watch for sparks and check if the wiring you worked with is getting warm. If either condition is noted, IMMEDIATELY disconnect the battery ground cable and read the Troubleshooting section.

TROUBLESHOOTING

1. If, when you reconnected the battery ground cable, you noticed sparks or any of the wiring getting warm, check that all connections are properly located, and insulated from grounding.
2. If the reading on the gauge stays at the lowest marked voltage when the ignition is switched on, then try reversing the wires on the gauge's connection posts "+ and −".
3. If the gauge reads lower than you expect, check all connections, especially those to a ground source. A poor connection causes resistance which gives a false low reading.

WATER/OIL TEMPERATURE — INSTRUCTIONS

Warning: If your car is microprocessor (computer) controlled or has an electric cooling fan, refer to the section on the front cover titled MICROPROCESSOR CONTROLLED ENGINES.

Temperature gauges measure the temperature of any liquid their sender tip is submerged in. An electrical temperature gauge is simpler and more versatile for installation than a mechanical gauge but is not quite as fast to respond to temperature changes and is not made with more than a 90° needle sweep, compared to a mechanical gauge which may have up to a 270° sweep.

PRECAUTIONS

1. A temperature gauge requires that its sender tip have a circulating flow around it to give an accurate reading. For this reason, a T-fitting cannot be used because it has no circulation therefore the original warning light sender cannot be operated off the same location. An additional location may be available on the cylinder head, intake manifold, or thermostat housing but caution should be used in that these locations may have different average temperatures than the original warning light sender location.
2. Do not over tighten the fittings or sender, particularly for mechanical gauges. The threads are designed to strip before the engine component can be damaged. The fittings use tapered self-sealing threads and do not require extreme force to seal properly.
3. Do not use sealing tapes or compounds on electrical senders as this will disturb their grounding connection to the engine resulting in false low readings.
4. Take caution when uncoiling and

routing the mechanical gauge's capillary tubing that you do not bend it too sharply or flex it too often. Any break in the inner tube will make the gauge nonrepairable. A replacement service is available only at the Actron factory service center.

5. Always install the adapter fitting into the engine first and then tighten the captive fitting (Diagram 8) on the capillary tube to avoid twisting the tubing.
6. Never install the captive fitting on the capillary tube directly into the engine without an adapter, as a proper seal will not be formed.

INSTALLATION

Note: If you are planning to use both an oil temperature gauge and an oil pressure gauge, some modifications may be necessary as there is only one available hole for both senders. Since the temperature gauge cannot use a T-fitting, Actron suggests that you install the oil temperature sender into the oil pressure warning light sender location in the engine block. Then obtain an adapter (which Actron does not manufacture) used for oil coolers which will give you an additional outlet for oil pressure.

For Mechanical Gauges:

1. Drain the fluid level in the system to below the sender's mounting location which is normally the factory's warning light sender location.
2. Route the capillary tubing through the mounting hole for the gauge and then through the firewall, protecting

the tubing from rough edges. Form at least one 3" or larger loop of tubing as it comes through the firewall and route the remainder to the sender mounting locations.

3. Remove the warning light sender and install the proper adapter fitting into the engine block. If the proper adapter fitting was not included with the gauge, obtain the CP7555 (NPT threads) adapter set.

Diagram 8

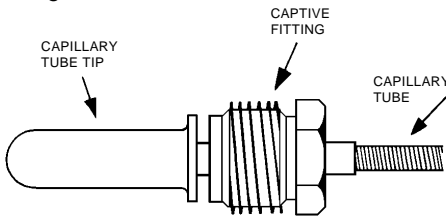

4. Insert the capillary tube tip into the adapter's hole and then tighten, with moderate pressure only, the captive fitting (Diagram 8) into the adapter. Do not over tighten. Sealing tape or compound may be used on either connection.
5. Complete the mounting of the gauge.
6. Refill the fluid level to its normal level.
7. Start the engine and observe the fitting connections for leaks and the gauge for proper operation.

For Electrical Gauges:

1. Drain the fluid level in the system to below the sender's mounting location, which is normally the factory's warning light sender location.
2. Remove the warning light sender and insulate the end of the sender wire. Install the proper adapter fitting (not included) into the engine block, if needed. Obtain either the CP7553 (NPT threads) or CP7573

(metric threads) adapter set, if an adapter is needed.

3. Install the gauge's sender into the warning light sender's mounting location in the engine block.
4. Run a length of 18-gauge insulated copper wire from the gauge's mounting location to the sender's mounting location.
5. Attach the 18-gauge wire onto the top of the gauge's sender.
6. Facing the back of the gauge, the connection post on the right is for the +12-volt power, the center post is for the ground connection and the left post is for the sender connection. After you have mounted the gauge, connect the sender wire to the left connection post as shown in Diagram 7, page 7. Do not over tighten.
7. Connect one end of another length of 18-gauge insulated copper wire to the center connection post, as shown in Diagram 7, page 7 and the other end of the wire to a good ground source.
8. Connect a third length of 18-gauge insulated copper wire to the right connection post as shown in Diagram 7, page 7, and the other end of the wire should be connected to the fuse box where the wires will receive +12 volts of power whenever the ignition key is in a START, ON or ACCESSORY position.
9. Refill the fluid level to its normal level.
10. Start the engine and observe the fitting/sender connections for leaks and the gauge for proper operation.

TROUBLESHOOTING

If your electrical gauge reads lower than you would expect, check all electrical connections, particularly grounding connections. Any poor connection will increase electrical resistance resulting in a false low reading.

OIL/AIR PRESSURE — INSTRUCTIONS

WARNING: If your car is microprocessor (computer) controlled or has an electric cooling fan refer to the section on the front cover titled MICROPROCESSOR CONTROLLED ENGINES.

Pressure gauges can measure the pressure present in a system utilizing air or liquids. An electrical pressure gauge is simpler and more versatile for installation than a mechanical gauge but is not quite as fast to respond to pressure changes and is not made with more than a 90 degree needle sweep, compared to a mechanical gauge which may have up to a 270 degree sweep. The factory warning light sender can be retained to operate the warning light with the use of a T-fitting which is commonly available at auto parts stores and is manufactured by Actron.

PRECAUTIONS

1. Check the owner's or service manual, or your local dealer, to be sure that the normal pressures during cold-start and fully-warmed operation for your engine or air system are within the gauge's range.
2. Be sure the tubing kit for the mechanical gauge is long enough for your application.
3. Follow the instructions carefully. A leak that goes unnoticed may lead to serious engine damage.
4. Do not use sealing tapes or compounds on electrical senders. This will disturb their grounding connection to the engine/system, resulting in false low readings.
5. Be careful not to crimp the tubing while unrolling it. Do not use any section of tubing with a crimp or kink in it. If the nylon tubing is a little awkward to use because of being rolled, heat it in boiling water and let the tubing cool while it is unrolled.

INSTALLATION

Note: If you are planning to install an oil temperature gauge as well as an oil

pressure gauge, read the Note under INSTALLATION in TEMPERATURE—WATER/OIL INSTRUCTIONS.

For Mechanical Gauges:

1. If you are monitoring a fluid system, drain the fluid level to a level below the warning light sender location.
2. Remove the warning light sender from the engine and install the engine fitting in the same location. If an adapter is required, first install the adapter (not included) and then the engine fitting.
3. Uncoil a few feet of tubing and slide the hex nut and ferrule over the end of the tubing as in Diagram 9. Insert the tubing into the engine fitting, and then tighten the hex nut into the engine fitting.

Diagram 9

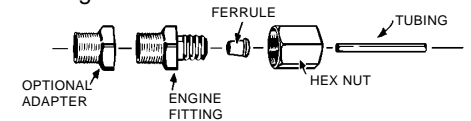

4. Optional T-Fitting (Diagram 10) — Install the nipple into the T-fitting and tighten the other end of the nipple into the warning light sender location. Install an adapter fitting first if needed. In one of the two remaining openings in the T-fitting, insert the engine fitting and then follow Step 3 to connect the pressure tubing. In-

Diagram 10

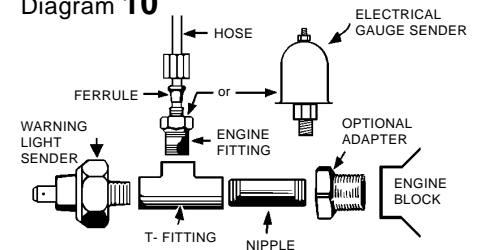

sert the warning light sender into the remaining T-fitting opening. Install an adapter fitting first, if needed (Actron does not produce metric fittings for the connection from a metric warning light sender to the T-fitting).

Diagram 11

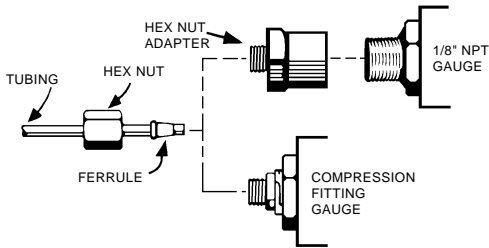

5. If the gauge has a 1/8" NPT fitting on the back (Diagram 11), install the hex nut adapter to it.
6. Route the remaining tubing through the firewall to the gauge mounting location. Leave at least one 3" or longer loop in the tubing before it enters the firewall and protect the tubing from rough edges of the firewall's hole.
7. Repeat Step 3 to attach the tubing to the gauge.
8. Complete the mounting of the gauge.
9. Refill the fluid level, if drained, to its normal level.
10. Start the engine and observe the fitting connections for leaks and the gauge for proper operation.

For Electrical Gauges:

1. If you are monitoring a fluid system, drain the fluid level to a level below the warning light sender location.
2. Remove the warning light sender from the engine and insulate the end of the sender wire if a T-fitting is not being used. Install the gauge's sender in the same location in the engine block. If an adapter is required, first install the adapter (not included) and then the gauge's sender.
3. Optional T-fitting (Diagram 10) — Install the nipple into the T-fitting and tighten the other end of the nipple into the warning light sender location in the engine block. Install an adapter fitting first if needed. In one of the two remaining openings in the T-fitting, insert the gauge sender. Insert the warning light into the remaining T-fitting opening. Install the adapter fitting first, if needed. (Actron does not produce metric fittings for the connection from a metric warning light sender to the T-fitting).
4. Run a length of 18-gauge insulated copper wire from the gauge's sender to the gauge's mounting location.
5. Connect the wire to the connection on top of the gauge's sender.
6. Facing the back of the gauge, the connection post on the right is for + 12 volts power, the center post is for the ground connection and the left post is for the sender connection. After you have mounted the gauge, connect the sender wire to the left connection post as shown in Diagram 7, page 7. Do not over tighten.
7. Connect one end of another length of 18-gauge insulated copper wire to the center connection post, as shown in Diagram 7, page 7, and the other end of the wire to a good ground source.
8. Connect a third length of 18-gauge insulated copper wire to the right connection post as shown in Diagram 7, page 7, and the other end of the wire should be connected to the fuse box where the wire will receive + 12 volts of power whenever the ignition key is in the START, ON or ACCESSORY position.
9. Refill the fluid level, if drained, to its normal level.
10. Start the engine and observe the fitting connections for leaks and the gauge for proper operation.

TROUBLESHOOTING

If your electrical gauge reads lower than you would expect, check all electrical connections, particularly grounding con-

nections. Any poor connection will increase resistance resulting in a false low reading.

VACUUM/ECONOMETER/BOOST INSTRUCTIONS

All of these type gauges measure the vacuum and/or pressure existing within the intake manifold of the vehicle. They use different ranges or markings to cover different needs and applications. A vacuum or econometer gauge measures the vacuum created as the engine draws air into its cylinders. A boost gauge measures the same vacuum, as well as the pressure when an external turbocharger or supercharger pushes air into the engine. An engine that is not supercharged or turbocharged will generally have a vacuum reading between 12 and 18" Hg (inches of mercury) at idle. Check the manufacturer's specifications for more exact readings for your engine at idle speed and other rpm. All of these gauges can aid you in monitoring engine efficiency, achieving the best fuel economy and noticing engine malfunctions immediately.

PRECAUTIONS

1. Be sure the source of vacuum you pick is a direct source and not in the brake booster or other accessory line, otherwise the reading may be inaccurate or unsteady.
2. Be sure your tubing and fitting connections are complete and sealed, for a vacuum leak will cause rough engine operation at idle, and inaccurate readings.

INSTALLATION

For Gauges With a Barbed Fitting:

1. Find a location on your intake manifold where you can either unscrew a plug in the manifold or find a vacuum hose you can cut to splice in a barbed T-fitting.
2. From the tubing kit, either screw in the barbed manifold fitting or splice the barbed T-fitting into a suitable vacuum line. This is done by cleanly cutting the tubing and then pressing each cut end of the tubing tightly into the opposing barbs of the T-fitting.
3. Unroll a few feet of vacuum tubing and press the end tightly into the remaining barb of the T-fitting.
4. Route the remaining tubing through the firewall into the gauge, leaving at least one 3" or larger loop in the tubing before it enters the firewall and protect the tubing from any rough edges of the fire wall. Press the tubing tightly onto the barb on the back of the gauge.
5. Start the engine and check for proper gauge operation. (Refer to the **How To Use** section).

For Gauges with 1/8" NPT (Threaded) Fitting (Diagram 11, page 12):

1. Find a location on your intake manifold where you can screw in the

engine fitting. Manifolds often have removeable plugs.

2. From the tubing kit, screw in the engine fitting into the manifold at the location you selected.
3. Uncoil a few feet of tubing and slide a hex nut and ferrule over the end of the tubing as shown in Diagram 9, page 11.
4. Insert the tubing into the engine fitting and then tighten the hex nut into the engine fitting.
5. Route the remaining tubing through the firewall to the gauge, leaving at least one 3" or larger loop in the tubing before it enters the firewall and protecting the tubing from any rough edges of the firewall.
6. Attach the hex nut adapter to the back of the gauge and then attach the tubing as in Steps 3 & 4. Refer also to Diagram 11, page 12.
7. Complete the mounting of the gauge.
8. Start the engine and check for proper gauge operation. (Refer to the How To Use section). For boost gauges, you will need to consult manufacturer's specifications for what rpm and pressure should be maximum boost and at what rpm the

engine transfers to boost from vacuum.

TROUBLESHOOTING

1. If your engine idles roughly, check the tubing and fittings for leaks. Sealing tape or compound can usually be used to solve these leaks.
2. If the gauge's vacuum reading changes when the brake pedal is pressed, then you will need to select another vacuum attachment point.

HOW TO USE

An Econometer is merely a vacuum gauge with different markings to directly indicate the economy benefits of each area of vacuum operation.

POOR (0-10") — Acceleration or Load requires a more open throttle position. Open throttle means more air & gas flow for more horsepower, reducing vacuum and fuel economy.

NORMAL (10-20") — Cruise condition, fairly steady throttle position, most useful economy range.

DECELERATION (20-30") — Throttle is nearly closed, momentum of vehicle or downhill grade carry vehicle forward. Little horsepower required, least fuel used.

FUEL PRESSURE — INSTRUCTIONS

Fuel pressure gauges measure pressure in the fuel system going to the carburetor/fuel injection system and the operation of the fuel pump. Check the manufacturer's specified fuel pressure for your system. Vehicles with fuel injection normally operate at pressures above 15 PSI. Although Actron does not produce a fuel pressure gauge that indicates greater than 15 PSI, a mechanical pressure gauge of any type can be used. Actron has models with ranges up to 100 PSI, 150 PSI or 200 PSI, depending upon the style.

PRECAUTIONS

1. **Because of the danger of fire from any possible leak, do not install this gauge within the interior of a vehicle.**
2. Use only rubber or metal tubing approved for fuel line use. The Copper Pressure Kit is the only tubing kit recommended by Actron.
3. Use only high quality connections and use sealing tape or compound on all threaded connections.

INSTALLATION

1. Choose a suitable location to splice into your fuel line between the fuel pump and the carburetor, the throttle-body fuel injector or the fuel distributor for a port-type injection system.
2. Obtain an appropriate metal T-fitting for your type of fuel line. For metal lines, use a T-fitting with three threaded connections such as Actron's T-fitting (Diagram 10, page 11). For rubber lines, use a T-fitting with one threaded fitting and two nipple-type connections for your size fuel line.
3. Disconnect the ground cable from the battery to avoid any chance of sparks during installation.
4. Cut or disconnect the fuel line at the location you have chosen.
 - A.) For systems with rubber fuel lines, connect the nipple-type T-fitting into the existing system by placing hose clamps over the separated ends of the rubber fuel line and then pressing the rubber tubing over the T-fitting's nipples. Position the hose clamps and tighten.
 - B.) For systems with metal fuel lines, slide a hex nut and a ferrule over the separated ends of the fuel line as in Diagram 10, Page 11. If the T-fitting does not have a compression fitting, then install one into it. Insert the tubing into the compression fitting.

Tighten the hex nut into the compression fitting.

5. Uncoil a few feet of the gauge's tubing, copper is recommended, and connect the tubing to the T-fitting with the same procedure used for metal fuel lines in previous Step 4. It may prove convenient to install the fuel pressure gauge directly into the T-fitting for underhood observation.
6. Route the tubing to the gauge's mounting location. If it has to pass through a firewall or bulkhead, leave at least one 3" or larger loop in the tubing before it enters the firewall or bulkhead and protect the tubing from rough edges.
7. Install the hex nut adapter into the 1/8" NPT fitting on the back of the gauge. Use the same procedure as in Step 4 to connect the tubing to the gauge as in Diagram 11, page 12.
8. Complete the mounting of the gauge.
9. Check that all connections are tight and sealed.
10. Reconnect the battery ground cable.
11. Start the engine and immediately check for fuel leaks, then check the gauge for proper readings.

TROUBLESHOOTING

If the gauge shows little or no pressure, check for kinks in the tubing or blockages at the T-fitting, or in the lines.

FUEL LEVEL — INSTRUCTIONS

Actron fuel level gauges accurately measure the depth, not the amount, of fuel left in the fuel tank. Because of the variety of fuel tank shapes, a universal gauge such as this Actron gauge cannot accurately compensate for the different rates that the fuel drops at various tank depths. This Actron Fuel Level Sender's instructions include adjustment procedures that are required to complete the installation.

PRECAUTIONS

1. The sender is not designed as a direct replacement for factory senders. Installation may require fabrication.
2. Because of the danger of working around gasoline, it is suggested you observe the following:
 - A.) All safety precautions in the front of this instruction booklet, including

the fire extinguisher availability and battery ground cable removal.

B.) Drain fuel from the fuel tank into a safe, vented container and remove the fuel tank from the vehicle if any modifications to the tank are necessary. Fill the tank with water to displace fuel vapors.

3. The fuel level gauge and sender require the best ground connections available for an accurate reading.

INSTALLATION

1. Read the Fuel Level Sender's instructions and follow them for installation of the sender.
2. Route a length of 18-gauge insulated copper wire from the gauge's mounting location to the connection on top of the sender and connect the wire to the gauge's sender.
3. Facing the back of the gauge, the connection post on the right is for the +12-volts power, the center post is for the ground connection and the left post is for the sender connection. After you have mounted the gauge, connect the sender wire to the left connection post. Attach the wire as shown in Diagram 7, page 7. Do not over tighten.
4. Connect another length of 18-gauge insulated copper wire to the center connection post as shown in Dia-

gram 7, page 7, and the other end of the wire to a good ground source. Scrape away paint or dirt from the surface of the ground connection.

5. Connect a third length of 18-gauge insulated copper wire to the right connection post as shown in Diagram 7, page 7, and the other end of the wire should be connected to the fuse box where the wire will receive +12 volts of power whenever the ignition key is in a START, ON or ACCESSORY position.
6. Double-check that the wire connections are located and attached properly and then reconnect the battery ground cable.
7. Refill the fuel tank, observing the gauge for proper operation as you do. Be sure that all water has been removed and the tank thoroughly dried before refilling.

TROUBLESHOOTING

If the gauge indicates too low a fuel level compared to the actual level, recheck all connections for poor contact, particularly the ground connections, as this will cause increased electrical resistance and false low readings.

If the gauge does not indicate full or empty at the proper fuel levels, recheck your adjustments to the sender so you are sure that it is getting full travel of the float arm.

FULL ONE (1) YEAR WARRANTY

Actron Manufacturing Company, 9999 Walford Avenue, Cleveland, Ohio 44102, warrants to the user that this unit will be free from defects in materials and workmanship for a period of one (1) year from the date of original purchase.

Any unit that fails within this period will be repaired or replaced at Actron's option and without charge when returned to the Factory. Actron requests that a copy of the original, dated sales receipt be returned with the unit to determine if the warranty period is still in effect.

This warranty does not apply to damages caused by accident, alterations, or improper or unreasonable use. Expendable items, such as batteries, fuses, lamp bulbs, flash tubes are also excluded from this warranty.

ACTRON MANUFACTURING COMPANY DISCLAIMS ANY LIABILITY FOR INCIDENTAL OR CONSEQUENTIAL DAMAGES FOR BREACH OF ANY WRITTEN WARRANTY ON THE UNIT. Some states do not allow the disclaimer of liability for incidental or consequential damages, so the above disclaimer may or may not apply to you. This warranty gives specific legal rights, and you may also have rights which vary from state to state.

actron 

ACTRON MANUFACTURING CO.
9999 Walford Avenue
Cleveland, Ohio 44102